

# Technical Data Sheet



## gem

532nm high spec OEM laser

50 - 600 mW

The gem is a high specification, single transverse mode CW green laser. This is an extremely small laser for this specification. Combined with the highly compact and efficient smd6000 power supply, the gem is geared towards product integration for end-user applications.

### Specifications

power	25 - 600 mW
wavelength	532 nm
beam size	1 mm
spatial mode	TEM <sub>00</sub>
ellipticity	<1.1
bandwidth	30 GHz
divergence	0.8 mrad
M-squared	< 1.1
power stability	< 2.0 % rms*
RMS noise	< 2.0 %
noise bandwidth	1 Hz to 6 MHz
coherence length	1 cm
pointing stability	38 urad**
polarisation ratio	100:1
polarisation direction	horizontal
beam angle	1 mrad***
operating temperature	10 - 40 deg C
head weight	0.7 kg
umbilical length	1.5 m
warm-up time	10 min

\* test duration 8 hrs

\*\* measured over 36 hours at 22 to 28 deg C

\*\*\* tolerance relative to head orientation

### Features

extremely compact design  
designed for OEM integration  
zero stress,  
permanently aligned cavity  
hermetically sealed  
OEM power supply  
extended warranty available  
single phase mains driven  
diode 18,000 hours MTBF  
direct modulation upto 30 kHz

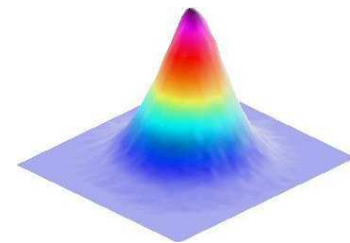

The gem has a diffraction limited beam, fitting a near perfect gaussian profile in both directions.

# Technical Data Sheet

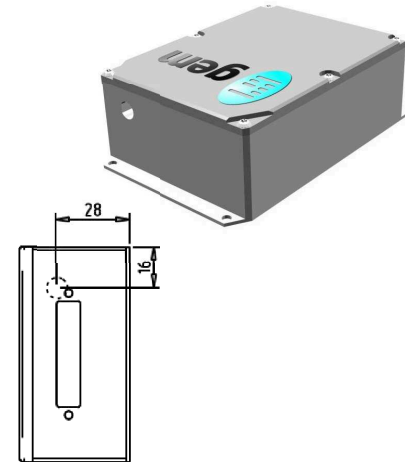
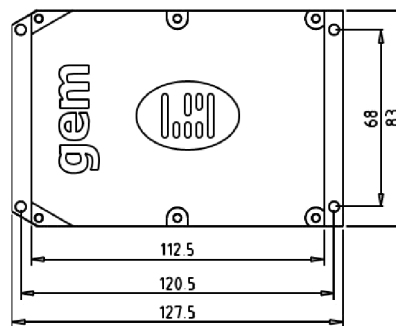
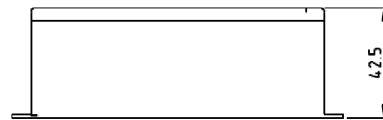

## Typical Applications

raman spectroscopy  
OEM integration  
fluorescence spectroscopy

## PSU options

smd6000



Allow 100mm clearance at rear for bend radius of umbilical.  
Drawings not to scale.

Laser Quantum has a policy of continuous improvement, therefore specifications are subject to change without notice.

Laser Quantum's scientific and industrial lasers are certified to comply with:  
IEC 60825 and Federal regulations (21 CFR - subchapter J) as administered by CDRH on shipments ordered after August 2 1976.

Copyright © 2006 [Laser Quantum Ltd]. All Rights Reserved.



**Photonic Solutions** Unit A, 40 Captains Road, Edinburgh, EH17 8QF, UK,  
Tel: +44 (0)131 664 8122 Fax: +44 (0)131 664 8144  
Email [sales@photronicsolutions.co.uk](mailto:sales@photronicsolutions.co.uk) Web [www.photronicsolutions.co.uk](http://www.photronicsolutions.co.uk)